

Build Your Own 4.25" Dobsonian Telescope



by Larry Robinson
edited by Robert Haler

**Build your own top quality telescope with
simple hand tools for as little as \$125.00.
No previous experience is required.**

Copyright © 1992-1998 Larry Robinson & Robert Haler
All Rights Reserved

Official 4 Inch Dob Web Site: www.lymax.com/cosmicone/4inchdob/
e-mail: 4inchdob@lymax.com

Copyright Notice:

**Copyright © 1992-1998 Larry Robinson & Robert Haler
All Rights Reserved**

This information may be used free of charge by individuals in the pursuit of their hobby of Astronomy. This document may be copied by astronomy clubs and distributed to the club's members free of charge. This document may NOT be reposted on any web site or altered in any way without the express WRITTEN permission of the copyright owner.

Reasonable portions of this document may be quoted for the purposes of critical review.

UNDER NO CIRCUMSTANCES MAY THIS INFORMATION BE USED FOR COMMERCIAL PURPOSES. IN PLAIN ENGLISH: IF YOU SELL THIS INFORMATION TO SOMEONE, YOU ARE STEALING.

Sorry we have to put such language in, but some people just don't get the concept of intellectual property.

FOREWORD

This is a digital reproduction of a work originally created by my friend Larry Robinson. This version is, with some minor editing, a faithful reproduction of the original document. Many improvements to the basic design described here have been made in the intervening years.

Please consider this to be a work constantly in progress. We already have quite a catalog of design improvements and alternative construction methods. As time permits, we will add this new content, along with photos and suggestions from people around the world. If you have an idea or comment, please let us know via email (4inchdob@lymax.com) or via snail mail at:

4 inch dob
Lymax's Earth, Sky, & Astronomy
P.O. Box 18537
Raytown, MO 64133

The official 4 inch dob web page:
<http://www.lymax.com/cosmicone/4inchdob/>

INTRODUCTION

Welcome to the world of telescope building. This manual was developed for those who want complete detailed instructions on how to build a low cost, yet top-performing instrument. It is an excellent first telescope and a useful portable addition if you already have a larger telescope. This manual can be used also as an educational tool to teach students, club members, and the general public how easy it is to build a telescope.

People who look through one of these little 4 1/4" reflectors for the first time are amazed at the image quality. This is due to the long focal length of the primary F10 (45"). Excellent examples and uses for long focal length telescopes of this type include:

- Detailed Lunar Observations with great resolution of surface detail
- High resolution planetary observing such as the Cassini Division
- Solar observing both in white light and H-Alpha filter systems
- Deep sky observing gives greater image contrast even in the city.

Because this scope is smaller, it is very portable so it can be taken out in the yard easily. It can be loaded in the family car at vacation time or just for weekend outings. Its small size makes it Excellent for children. It is usually the one telescope at the star party that all the kids flock to because they can observe without ladders or boxes.

This manual contains all of the details on materials, tools, and a step by step easy to understand procedure with twenty diagrams for easy reference. Total construction and assembly time is about twelve hours.

TOTAL COST FOR COMPLETE TELESCOPE IS APPROXIMATELY \$125.

TOOLS NEEDED

There are a few tools needed to make building your telescope easier. Not all of the tools listed are absolutely essential. However, if you have them, can buy them, or can borrow them - it will be much easier to get the Job done. I have listed most of them here:

Pencils

Straight Edge 4 Feet Long

Square

Old Wooden Ruler (or a cheap new one) that you don't mind drilling holes in

Circular Skill Saw with a plywood or combination blade

Saber Saw

Hand Drill

Drill Bits:

Pilot hole bit for 1 1/4" sheet rock screws (*regular bit the diameter of the screws with no threads*)

1" spade bit

3/4" spade bit

1/16" bit

3/8" bit

5/16" bit

1/2" bit

1/4" bit

3/32" bit

2" hole saw bit (*if making a 1 1/4" focuser*)*

1 1/4" hole saw bit (*if making a .965" pvc focuser*)*

Phillips head screwdriver

Slot head screwdriver

Putty knife

Small paint brush

Handsaw

Caulking gun

Hammer

*If you decide to purchase a focuser from any manufacturer, be sure to check their specifications for the proper size of hole to drill.

MATERIALS NEEDED

Except for the mirrors, all of the materials needed to build this telescope are generally available at your local hardware store or lumberyard. A few things like two 33 1/3 LP albums and the salvaged .965" focuser require a little more ingenuity. Focusers from old Japanese 60mm refractors work fine. If you can't find a salvaged focuser, you can make a focuser out of pvc pipe fittings using the plans included here.

The piece of PVC well casing pipe for the main telescope tube might be a little hard to find. Perhaps a few calls to the Well Drillers listed in your local Yellow Pages might turn up something. You will need a 5 foot piece. Buying a whole piece of 5" well-casing pipe might be expensive, and suppliers may require you to buy a 10 or 20 foot piece - so definitely look for scrap.

Order your mirrors first. Delivery takes two or three weeks. If you pay by check they have to hold off shipment until your check clears the bank, usually ten days. So if you are in a hurry, pay by money order, credit card, or cashier's check. A 4 1/4" mirror would be an easy size to grind yourself, but after buying the blanks and polishing materials - then paying for having the mirror coated - you will probably have spent about the same amount of money as it would cost to buy one ready made.

A major supplier of the 4 1/4" mirrors is Edmund Scientific, 101 East Gloucester Pike, Barrington, New Jersey 08007-1380, telephone number 609-573-6250, fax number 609-573-6295.

Edmund makes both a paraboloidal and a spherical 4 1/4" mirror. Small diameter mirrors work almost the same if figured to spherical shape as they do if paraboloid in shape. There is a complicated equation that proves this, but the real test is the view in the eyepiece. The spherical mirror is a few dollars cheaper - so you decide. A single stalk mounted diagonal mirror works fine. This may be a discontinued part number, but Edmund can make them up anyway. The new version is threaded on the end of the stalk making it a snap to mount.

Here are the part numbers and prices I used to order my mirrors from Edmund Scientific:

Part No: 50051 Mirror spherical 4-1/4 W10	\$69.60
Part No. 60086 Mounted Diagonal Mirror	\$ 9.95
Total Product	\$79.55
<u>Shipping and Handling</u>	<u>\$10.25</u>
Total Cost	\$89.80

The people at Edmund are very helpful and willing to extend discounts to quantity purchasers for workshops or group. You may want to ask for Don Netter – the gentleman I dealt with.

Two 33 1/3 LP records

These can be any style or song, as you will use them as bearings between the base and the mount! Make sure they are the big album sized ones, 45s are too small.

4ft x 4ft x 3/4" Plywood

Buy one piece of 3/4" outdoor grade AC plywood (good on one side) 4ft x 4ft. You don't need a whole 4ft x 8ft sheet unless you plan to build two telescopes. You actually won't use all of the 4 x 4 sheet, but this way you have some spare in case you goof up a piece or two when cutting or assembling. Most hardware stores and lumber yards sell 4x4 sheets of plywood.

One quart of paint primer (optional)

You must prime all wooden surfaces to prevent moisture from rotting the wood over time. You will paint over the primer. If you decide to use interior grade plywood then the paint primer coat becomes very critical. I recommend buying a quart of Kilz primer. This stuff is white in color. A quart is enough to paint primer on two or three telescopes.

Two pounds of 1 1/4" sheet rock screws (also called "bugle head" screws)

These little black Phillips head screws are the best thing in the world for assembling wooden parts. Buy **ONLY** 1 1/4" screws. Most everything we will be putting together will be 3/4" pieces and anything longer than 1 1/4" will poke through two pieces of this thickness of wood. These screws are usually sold by the pound. Go ahead and get two pounds. You will have some left over, but they are handy for everything.

Carpenters Glue (small bottle!)

Get a little bottle of yellow Elmer's wood glue or some similar brand of Carpenters Glue. You won't need much, so buy the smallest bottle.

Coarse Grit (40 or 60) Sandpaper (3 or 4 8x10" Sheets)

Since you are going to prime and paint everything anyway, the only sanding you need to do is for rounding corners and smoothing. The best thing for this is very coarse sandpaper - the coarser the better. (If you are a perfectionist - and are building a walnut or oak telescope - you will want five grades and spend hours sanding out scratches. Before you finish with all of that extra sanding, you will wish you had painted.) But if you are going to paint, use coarse sandpaper and save some time and elbow grease. Three or four 8x10 inch sheets are enough.

1/2" nail-on nylon furniture coasters – 6 pieces

The Dobsonian mount we are building uses rings of pvc pipe traveling on nylon coasters for the vertical (altitude) movement of the tube. Nail-on type nylon coasters are used on the bottoms of chairs and tables to make them easy to scoot around on the floor. These little coasters are perfect for bearings and they never wear out. If you were building a bigger scope, you might think about using Teflon pads. Besides being harder to find, Teflon is more expensive. Teflon is really neat stuff – and it works great for larger scopes - but seems to be *too* slippery for this 4 1/4 " telescope design. Nylon is the best choice for this application. If you can't find 1/2" nylon coasters, then any larger size will work up to 7/8". You will need six of these, but they usually come 4 to a package so you will have to get two packages.

Four 1/4" x 20 T-Nuts

Included is a drawing of a T-Nut so you will know what to look for. They are used to put threads into a hole in a piece of wood so you can screw a bolt in. In this case a 1/4" x20 bolt. For those of you who don't know what 1/4" x 20 means: 1/4" means the bolt is 1/4" in diameter and 20 means it has 20 threads to the inch.

One 3/8" x 18 T-Nut

This is the same kind of T-Nut except bigger. It will work with the 3/8" bolt used to secure the mount to the base which allows it to swivel.

One 3/8" x 3" Bolt

Get the one with threads only half way up the shaft and a hex head.

One 3/8" Washer

Make sure the bolt will go all the way through it including the smooth part of the shaft.

One 3/8" Wing Nut

Pretty obvious, huh? Make sure it screws on the bolt.

Four 1/4" x 20 x 3" long bolts

Slotted head carriage bolts work best. Make sure they are threaded all the way along the shaft.

One 1/4" x 20 Hex Nut

Self explanatory.

Three 1" long, skinny wood screws

These can be any style, but round slotted or Philips heads are nice. Get ones that are threaded all the way and are of a uniform diameter.

Two Small “Eyehead” Screws, 1/2” and 1/2”

One should have an eye that is about 1/4" in diameter and the other about 1/2" in diameter. Get the kind with wood screw type threads. These will be used to make a simple finder. (you don't need these if you are going to use a different type of finder.)

1/2 Pound of 1 1/2' Long Finishing Nails

These are used to mount the rings and may be helpful in securing pieces of wood until they are glued and/or screwed together. **Do not** rely on nails to do the job of holding your telescope together.

Tube of Silicon Rubber Sealant or Glue (RTV)

This is used to mount the mirror to the mirror cell and perhaps glue in the focuser. You want the clear, 100% silicone type – **not** caulking with latex or colored silicone.

One Can of Flat Black Spray Paint

This is used to paint the inside of the tube to prevent reflective glare.

Wood Filler Putty

The smallest size is ok.

Nylon Insert Cap Nut Size 8-32

This is used to lock the diagonal stem onto the tube or focuser.

FOCUSER OPTIONS (Choose One)

CUSTOM MADE .965" FOCUSER:

These parts are only needed if you are going to make your own focuser out of PVC pipe fittings for use with .965" eyepieces.

Two 1' long 8-32 set bolts with thumb screw tops

Make sure these have flat tips not sharp points.

One piece of 1" diameter Schedule 40 (thick wall) PVC pipe about 6" long

This is for a .965" focuser draw tube.

One piece of 1 1/4' Schedule 40 PVC about 6' long

This is the focuser body.

PVC Cement and Primer

Smallest sizes available – you will need very little.

CUSTOM MADE 1 1/4" FOCUSER:

If you prefer to make a 1 1/4" focuser, this can be done best by purchasing a 1 1/4" x 6" long extension tube for a sink drain in the plumbing department of your local hardware store. (note: These drain extensions or "tail pieces" come in at least 2 different sizes, so make sure you get the right size.) It will need to have about 2" cut off the end with pipe cutters or a hacksaw. Also, you can purchase a FEN waste connector for the 1 1/4" extension tube to fit in. This has a plastic nut for tightening around the tube to lock the focuser in place at the right height.

These items cost:

Ext. tube with lock nut (Ace Hardware part no 44478)	\$3.37
<u>FEN Waste Tube (Ace Hardware part no 40310)</u>	<u>\$5.19</u>
Total Cost For Homemade 1 1/4" Focuser	approx. \$8.56

Store Bought Focuser:

You can purchase a complete 1 1/4" focuser from one of the astronomy supply houses for anywhere from \$35 up to over \$100. The homemade job works just fine for a whole lot less. In the eyepiece sources section of this manual is a list of several well known suppliers.

That's about it for the materials required to build this telescope. The rest is pretty easy.

HARDWARE STORE SHOPPING LIST

If you take this list with you to the hardware store, you will cut your telescope building time in half. It seems like I spent all my time going to the store for some little item I forgot the first time.

One 4ft x 4ft x 3/4" sheet of plywood – outdoor grade A/C
One quart of primer paint – Kilz preferred
Two pounds of 1 1/4" bugle head sheet rock screws
Yellow Carpenter's Glue - smallest bottle
Coarse Grit (40 or 60) Sandpaper - 3 or 4 8x10" sheets
Six 1/2" nail-on nylon furniture coasters – because of packaging you may have to buy 8
Four 1/4" x 20 T-Nuts
One 3/8" x 18 T-Nut
One 3/8" x 3" Bolt – hex head, half threaded shaft
One 3/8 Flat Washer
One 3/8" Wingnut – make sure it fits the bolt!
Four 1/4" x 20 3" long bolts – slot head carriage bolts, entire shaft threaded
One 1/4" x 20 Hex Nut
Three 1" length skinny (1/8" dia. w/thread) wood screws – domed Philips heads, straight shafts
Two small eyehead screws – one each 1/4" eye and 1/2" eye, wood screw type
1/2 pound of 1 1/2" long finishing nails
Tube of Silicone Rubber Sealer/Adhesive – 100% clear silicone
Can of flat black spray paint
Nylon insert cap nut size 8-32
Wood Filler Putty

NOTE: If you plan to build a custom focuser add the materials to build your choice from the items listed on the previous page.

LAYOUT AND CUTTING OF THE WOODEN PARTS

It is important to lay out the parts on the 4 x 4 sheet of plywood very accurately. If the parts are laid out with incorrect dimensions, they won't fit together properly later on. To help in this, refer to drawing Diagram 1. It is easier to draw on the smooth side of the plywood. Definitely use pencil, since ink won't erase. The sharper the pencil, the more accurate your measurements will be. So sharpen your pencil frequently while drawing the layout.

IMPORTANT: While laying out the plywood parts, be sure to leave room for the saw kerf (material removed by the saw blade). If you use a skill saw with a typical blade, it will make a kerf approximately 1/8" wide – so leave 1/8" between adjacent parts as you lay them out.

Use a straight edge and a square to lay out the square and rectangular parts. It is easy to mess up if you don't constantly check for squareness on all the corners and then you end up with rectangles of wood that are really parallelograms and they don't fit together correctly.

For the circular parts use an Old Wooden Ruler and drill a 1/8" hole at the 1" mark. Drill other holes as needed for different radii. Use a 1 1/2" finishing nail as the center of the circle. Just tap it into the plywood so it is firmly anchored, put the hole at the one inch mark of your ruler over the nail and then put your pencil in the appropriate other hole to draw your circle. For example, the six inch diameter circle which is cut out between the tops of the two sides of the mount would be drawn by placing the pencil into a hole drilled at the 4" mark. Four minus one is three, so the radius you draw will be three inches creating a 6 inch circle. Measure carefully to place the center 4 1/2" from each end of the line between the two pieces. Simple math

Common errors to watch for:

Forgetting the center hole is at one inch and making circles two inches too small.

Not allowing enough room for the circle and running off the edge of the board or overlapping the line of another piece.

Not spacing the three circles for the tube ends and mirror cell close enough together and running out of space for the third circle.

Start out by drawing the circle very lightly first, then after inspection, go around again darker if it's right. Even though you are using pencil, it is hard to erase on plywood. Later, when you are cutting out those circles, it is easy to get off track with all those wrong circle lines in the way. Also, it is a good idea to lightly circle the correct center hole for later drilling.

There are a few small parts which can be cut from the scrap after all the main parts have been cut out. These are shown at the bottom right corner of Diagram 1. The little 1.5" square pieces are the feet for the bottom of the base. By using three feet, your telescope will always sit solidly on grass or uneven ground (just like a tripod). The little T-shaped piece is a knob for the front tube plug to make it easy to put it in and take it out. The two pieces with the four 1" holes in them are eyepiece holders for extra eyepieces you might need while observing. This is a handy accessory, because it is such a hassle trying to find eyepieces in the dark. You don't want to just set them on the ground where they will get dirty. If you are using a 1 1/4" focuser, make the holes 1 5/16" in diameter. Layout the holes in the eyepiece holders so that there will be plenty of room around each so the eyepieces don't crowd each other.

Now cut out all the pieces! The best way to cut plywood is with a circular skill saw for the straight lines and a Saber saw for the circles and curved pieces. It is tricky to cut out some of the pieces, **so read this carefully before you proceed.**

It is hard to cut out plywood if it is up on saw horses - because the cut piece is always trying to fall off before you have finished cutting it off. This usually results in a sloppy cut or bodily injury. The smart way to cut plywood is flat on the driveway with three or four boards at different spots under it so your saw blade doesn't hit concrete. Also use a plywood blade for smoother less splintery edges. A plywood blade has more teeth on it than a regular blade.

Cut the two long lines across the board first. It is a lot easier to handle the resultant smaller pieces, plus you aren't sawing into the adjacent pieces when you come to the end of a line. Go ahead and cut across that 6" circle between the two pieces labeled "side". That circle isn't used for anything, it's scrap.

Cut the sloped sides of the struts with the saber saw, not the circular saw, otherwise you will overlap and mess them up. Cut the handles out with the saber saw too. You will have to drill a starter hole in the center.

Naturally, the circles should be cut out with the saber saw too. When you get to that circle within a circle you will have to drill a starter hole. Be sure to drill it outside the line of the center circle. The inside edge of the base ring will not be visible but the bottom ring of the cradle will be very visible. You don't want some ugly notch whacked out of the side of it. You will be constantly explaining your mess-up to people who don't already know.

Also, when cutting with a saber saw - **go slow!** Stay on the lines. If you try to go too fast, you'll get off track.

Critical: With the saber saw, make sure you are cutting straight up and down and no angling of your cuts top to bottom. Check your blade adjustment on your saber saw before you start rutting. This is absolutely critical on that 6" semi-circle you will be cutting out of the two pieces labeled "side". This is the surface the bearing rings ride on and it has to be square with the face of the board for your telescope to work right.

If you can't cut curves well with a saber saw then cut outside the lines a little bit and sand it down to the lines to make it exact. You will be doing a lot of sanding on the edges of the circles anyway, particularly the little circles that go in the tube. Here's where that coarse sandpaper comes in handy.

It is best to use a 1" spade bit drill to cut the holes in the eyepiece holders if you will be using the .965 focuser. A 1 1/4" spade bit can be used for the 1 1/4" version, but you will have to sand it out to 1 5/16".

When you finish cutting everything out, sand the edges a little to get rid of splinters. Don't sand heavily at this point. Your telescope is now ready for assembly.

ASSEMBLY OF THE WOODEN PIECES

You are going to assemble three main sub-components:

The Tube Box holds the telescope tube. Our tube is a piece of 5" pvc well casing pipe.

The Cradle or mount is a 24" tall platform that the tube box sets in. This is what the tube and tube box swivel on for up and down (altitude) motion.

The Base Plate is what the cradle or mount swivels on for side to side (azimuth) motion.

A few words about how to properly assemble plywood: Drill it. Glue it. Screw it. If you use nails, they are just to hold a part in place *temporarily*, so you can drill it, screw it, and glue for *permanent* assembly. Drill pilot holes for nails too. There are special drill bits made for drilling holes for screws that automatically countersink (make a depression for the slanted heads). It's a good investment. Countersink all screws that will hold together glued pieces unless directed to do otherwise. That's deep countersinking - So you can fill and sand to make that screw disappear! Same for nails – you can sink the finish nails with a "nail set" or punch. Other screws at removable places - like the top of the tube box - should be flush, but not deeper than the surface. Avoid electric screwdrivers. They are easy to use, but they tend to mess things up – **a lot**. We are building a telescope here - not a deck. If you drill your holes out properly, a regular screwdriver works fine. If you have trouble, run the threads of your screw over a bar of soap. They will go in *much* more smoothly with soap on the threads. Drill it and soap it, before you glue it and screw it, the old fashioned way - with a screwdriver!

Assembling the Tube Box is easy. Refer to the blow-up in Diagram 2. Face the nicer side of the plywood out. Glue and screw the handle on the top piece first. Then glue and screw the sides to the bottom piece. It may help to use 1 1/4" finishing nails first. Notice that the top is not glued. That's so you can remove it to put the tube in. If you laid everything out right and cut along the lines then the box should go together easily. When you are through assembling the tube box, fill all of the holes with wood putty except for those holding on the top. Really press it in and mound it up. Fill all the cracks between the pieces except for those between the sides and the top. Set the tube box in an undisturbed location so the putty can dry. Out in the yard in the sun would be good.

Assembling the Cradle Mount is not too much harder than the tube box, just a few more pieces. Refer to the blowup in Diagram 3. Face the nicer side out on the sides and front. Face the nicer side of the bottom up into the interior of the box. Face the nice side of the eyepiece holders up. Face the nice side of the bottom ring up.

Before You Assemble the Cradle, drill a 3/8" hole in the center of the bottom piece. Make corner to corner lines to find the center of the bottom piece. Start out by putting the handle on the front piece (nice side) in the center and two inches up from the bottom. This is how you will transport the cradle and base assembly and most of the weight is near the bottom so the handle must be too.

Next, attach the struts to the center bottom of the sides. Run the screws from the inside of the sides into the struts. Also attach one of the eyepiece holder parts to each side of the cradle, gluing between pieces and screwing from the inside. Center these about three inches down from the semi-circular cutouts with the good side facing the semi-circle.

Now attach the sides to the bottom piece. The sides go on the outside of the bottom piece, not on top of it. This is critical!

Finally attach the front to the sides and bottom with glue and screws.

Turn the whole works over and coat the bottom, including the bottom of the struts, with glue.

Now find the bottom circle of the cradle. It's the smaller of the two big circles you cutout. Drill a 3/8" hole through the center. Put the 3/8" bolt in the bottom circle. Pick the circle up with the bolt in the hole and lower it onto the cradle mount - putting the bolt through the hole in the bottom. Drill and screw the circle to the base and struts. (See Diagram 4.) **Do not** countersink the screws - just put them flush. (You don't want screws poking out the bottom piece on the other side.)

Fill all the holes with wood putty and set in the yard with the tube box to dry.

Assembly of the Base Ring is simple. Place the big circle good side down. Glue the bad side of the ring to the base and screw it in with six screws. **Do not** countersink these screws. You do not want them to poke through the other side. Next attach the feet on the ring 120 degrees apart with glue and one screw each. See Diagram 5.

Drill a 1/2" hole in the center base circle and hammer the 3/8" T-Nut in from the bottom. Don't put it in from the top!!! It goes on the same side as the feet.

Don't worry about filling holes on the Base piece. All those holes will face the ground.

Find the mirror cell. It is the smallest circle you cut out. Make sure it fits very loosely inside your tube. It should be no more than 4 3/4" in diameter. When the mirror is mounted on the mirror cell you do not want it to touch the inside of the tube. Using a 3/4" paddle bit in your drill, drill a 1/16" deep *depression* (not a hole!) at the center of the mirror cell. Then using a 5/16" regular bit, drill out the center all the way through. Install a 1/4" - 20 T-nut in this hole. See Diagram 6 for details. Paint the mirror cell with flat black spray paint all over trying not to get paint in hole.

Find the back plug. It is one of the 5" diameter circles you cut out. Either one will work. Check to see if it slides into the tube easily, but not too loose. You want a close fit, but not a binding one. Sand it until it fits right. Drill a 1/4" hole all the way through the center. Next, install three T-Nuts exactly the same way you did on the mirror cell spacing them equally around the center halfway between the center and the outside edge. See the Diagram 7 for details. Paint the side with the T-Nuts using the flat black: spray paint. Paint the other side with primer. Don't paint the edges.

Finally, attach the knob to the front tube dust plug as shown in the Diagram 8.

Sand everything until the sharp corners are gone and the rings look round. It is worth the extra sanding to make the base circle and ring look like a single piece. This is fairly easy if you have a belt sander. Otherwise a wood rasp might work for the rough stuff. Sand the front dust plug so it is very loose and bevel it down as shown in Diagram 8. You are going to cover the edge of the dust plug with felt for a tight fit, so you need to take enough wood off to allow for the felt.

After everything is sanded, paint every wood surface with primer, except for those pieces you have already spray painted flat black. Try not to get primer in the center holes in the bottom of the cradle mount or base assembly.

While the primer is drying you can get the tube ready.

Preparing the Tube

Cutting pvc pipe is a little tricky, but not if you know a couple of tricks!

Always draw a line around the tube first. This is easily done using a piece of heavy paper or thin cardboard as a straight edge. Wrap the paper around the tube where you want to cut it and draw along the straight edge until you have a line all the way around the tube. If you held the paper tight, your line will be square to the tube.

Use a handsaw to cut the pvc. It's soft as butter once you get started. Always cut on one side only and work your way around the tube until you arrive back where your cut started. It's best to do this with the tube setting flat on the ground. Just like plywood, the tube will get away from you if it's elevated.

After you have cut the tube, use a file to clean it up on the ends. Coarse sandpaper works well too.

The main tube, as it comes from the supplier or scrap heap, is probably not square on either end. Therefore, your first cut should just take a little (1/4"-1/2") off one end to square it up. Mark it with paper as described above before you make this "clean up" cut.

Next mark the tube for a 1" ring (on the end you just squared up!) and cut it off - then mark and cut a second 1" ring. These will be your bearing rings for the tube box.

Now measure out 50" from the good end and mark and cut the tube off square.

Wash the tube thoroughly. Swab out the inside with soap and water, then hose the whole thing down so it is 100% soap free. Stand it on end to dry.

When the tube is thoroughly dry, paint the inside with flat black spray paint. You can shoot the paint from both ends and do a decent job of coating the entire inside. Some inventive scope builders have rigged up long wooden handles – allowing them to lower the spray can down into the tube. We will try to include a design for one of these "stalk sprayers" in a future revision. Until then, spraying from both ends works pretty well on a scope this size.

Now things get a little different if you are making your own focuser vs. installing a purchased one.

Procedure For Making And Installing Custom PVC .965" Focuser:

Drill a 1 1/2" hole in the main scope tube, placing the center of the 44" from one end of the tube. Use a hole saw drill bit for this operation. Rasp out the hole to fit the 1 1/4" pvc pipe. Cut off a 2" long piece (make sure the ends are square!) of the 1 1/4" pipe to use as the outer part of your focuser. Drill a small hole in this 2" long piece about 1/4" from one end and thread in the one of the small thumb screws you bought. Now cut off a 5" piece of the 1" pvc (square on both ends) and drill a little hole in it 1/4" from one end. Put the other thumb screw in to hold your eyepiece in place securely. This is the draw tube of your focuser and it will slide inside the 1 1/4" pvc nicely, See Diagram 9. The outer piece of 1 1/4" will be glued in place with pvc cement after you have mounted the diagonal. **Don't Glue the Focuser In Yet.**

Procedure for making and installing Custom 1 1/4" Focuser:

Drill a 2" hole (make sure your FEN waste tube part is exactly that size) in the main scope tube, placing the center of the 44" from one end of the tube. Use a hole saw drill bit for this operation. Trim about 2" off the end of the extension tube. The waste tube piece should fit snugly in the 2" hole and the extension tube snugly in it. Both pieces have threaded rings for adjusting tension. **Don't Glue the Focuser In Yet.**

Procedure for Installing a Store Bought Focuser:

Be sure to check the specifications or measure for the right hole size before drilling. These focusers usually bolt on, so you will probably need to drill holes for the bolts and use nuts and bolts to install it. In any case, position the focuser so that it's center is 44" from one end of the main scope tube. **Don't Permanently Mount the Focuser In Yet.**

Now you are ready to paint the tube and the mount. You do not need to prime the pvc.

PAINTING

There is a great type of paint for telescopes called Fleck Stone. This paint kit is a three step paint process that results in a rough, almost stone looking finish that appears to be scratch and dent resistant and makes a telescope look like a professionally made instrument.

To use Fleck Stone you first need to paint the tube and mount with a complementary color of spray-on Enamel. It takes two cans. Remember to paint the front of the tube dust plug on the side with the knob and the outside of the rear tube plug. That's the side opposite the three T-Nuts. Next you spray on the water-based Fleck Stone material that comes in the Fleck Stone kit. After that dries, you spray on the clear acrylic over coat that comes in the Fleck Stone kit. This clear coat makes the surface waterproof and hard. It takes two Fleck Stone kits to paint the telescope. Each kit costs about \$9.00. It is available at most lumberyards and paint stores. Fleck Stone comes in a variety of colors and the cap of the can shows what the finished product looks like. Appearance can be varied by using a different colored enamel as a first coat.

If you don't use Fleck Stone, then any enamel paint will work, although a final coat of spray on clear acrylic is still recommended as a moisture barrier.

After you have finished painting, let everything dry hard overnight before you try to assemble the telescope.

MOUNTING THE PRIMARY MIRROR

After you have received your mirror, the mounting of it on the cell is best done in the house. You will need the mirror cell with T-Nut installed and painted black, your mirror, the tube of silicon rubber cement, a caulking gun, and three 1 1/2" finishing nails. No, we aren't going to nail the mirror on. The finishing nails are used as temporary elevating spacers.

Set the mirror cell on a flat surface with the T-Nut facing up. Put three 1" inch diameter globs of silicone on the surface of the mirror cell an equal distance from each other, the center, and the sides. Apply the silicone carefully, trying to make each blob the same size. Place a finishing nail on its side between each glob of silicon with the point facing the center of the mirror cell and the head of the nail overhanging the side. Lower the mirror onto the silicone globs until it rests on the nails. See Diagram 10. Let this set undisturbed for at least 24 hours, then remove the nails and let it set for another 12 hours or more. When it has set up, the silicon forms a resilient pad for the mirror anchoring it firmly to the mirror cell without putting any distorting stresses on the glass. This is the best mirror mount going.

FINAL ASSEMBLY

All of the paint is dry and looks great. It is important, during the final assembly, that you not mess up that nice paint job. So set everything on pads of towels or old newspapers while you work on it.

Remember those one Inch rings of 5" pvc you whacked off the tube when you were cutting it to length? You will need to set them out now. These are the bearing rings for the tube box assembly and we need to mount them now.

First, make sure they set flat on at least one side, preferably both. If necessary, sand them until they do.

This is the one time in the assembly process we are going to use nails instead of screws. There's not enough room for screws.

Drill six equally spaced 3/32" holes through the center of the edge of each pvc ring. See Diagram 11. This should be the right size for the 1 1/2" finishing nails to go through loosely. You do not want a tight fit.

After both rings are drilled, set your tube box. Set it on it's side and very lightly draw a line in pencil across opposite corners to find the center. Measure 2 1/2" from the center to four equally spaced spots and make another light pencil mark. This is how you line up the ring on the center of the side of the tube box. You should be able to see the marks on the inside of the pvc ring when you set it on the side of the tube box. When it is lined up, you nail it on with the 1 1/2" finishing nails. Don't glue it. Turn the tube box over and nail on the other ring in the same manner. See Diagram 12.

Find your base plate and set it on the floor. Get the two 33 1/3 LP records you will use for bearings between the base plate and the cradle mount. Set them flat on a scrap of wood and drill the centers out carefully with a 3/8" drill bit. Set one LP on the base plate lining up the holes. Smear some vaseline or light oil on the face of the LP. Set the other LP on the first one again taking care to line up the holes. Now set the cradle mount on top of the LP's lining up the 3/8" hole carefully. Put the 3/8" washer on the 3"x 3/8" bolt and insert the bolt into the hole. Screw it into the T-Nut until the cradle mount swivels smoothly on the base without wobbling. Do not over tighten. Turn the whole assembly upside down and thread the 3/8" wing nut onto the bolt sticking out the bottom of the T-Nut. Tighten the wing nut as tight as you can. The wing nut prevents the bolt from unscrewing from the T-Nut as you turn your telescope from side to side. See Diagram 13 showing assembly of mount.

Find the 1/2" nylon nail-on coasters you bought. You need six. Using your thumb, press them into the wood of the semi-circle one inch from the top on each of the 4 corners. See Diagram 14. The other two go inside on the sides of the cradle centered just under the bottom of the circle. If they don't push all the way in by hand, then use a hammer...gently.

Your tube box should now set right down in the cradle with the rings on the glides. See Diagram 15. See how smooth the travel is. If it doesn't fit, then you've cut or assembled something incorrectly. This is sort of a moment of truth on how well you have followed the instructions.

Now take the top off the tube box by removing the three screws on both sides. Aren't you glad you didn't glue it now. Put the tube into the box with 18" from the back of the tube to the box. The back of the tube is the end without the focuser hole in it. Put the tube box lid back on with screws. It should grip the tube tightly. This is another advantage of using Fleck Stone paint. The rough surface creates lots of friction. Don't try to slip the tube into the box without taking the top of the box off. This will mess up the paint job on the tube.

Now set the tube box with tube in the cradle where it goes with the front of the tube resting gently on the front of the cradle. Pad it with a rag, if you don't want scratches.

Now go get your mirror cell with the mirror mounted on it. **Be careful not to touch or otherwise damage the mirror surface!** You will also need the four 3" x 1/4" - 20 bolts, the 1/4" hex nut, and the back plate.

Screw a hex nut onto one of the four 1/4" - 20 x 3" bolts 2/3 of the way back to the head of the bolt. Using this bolt assemble the mirror cell to the back tube plug through the center holes of each. Be sure to orient the back plug with the 3 T-Nuts facing into the tube. Look at the diagram. **DO NOT THREAD THE CENTER BOLT INTO THE MIRROR CELL TOO FAR – IT MUST NOT TOUCH THE BACK OF THE MIRROR!** After the center bolt is threaded into the T-Nut in the mirror cell about 4 or 5 turns, install the other three bolts in the back plate and screw them all the way through until they make contact with the wood of the mirror cell. See Diagram 17.

The three bolts around the outside are the collimating bolts. Turning them one way or the other lines up the primary mirror straight with the tube and your diagonal. Do not install the main mirror cell yet.

Next install the single stalk diagonal by drilling a hole in the main tube or in the edge of the purchased focuser at the appropriate spot. The important thing to remember is the diagonal mirror needs to be directly under the center of the focuser. See Diagram 18. It is best to thread the hole you drill in the pipe or focuser to match the threads on the diagonal stalk. If unable to do this, then buy a nut to go on the stalk on the inside of the tube. Use the nylon insert cap nut on top.

If you are using a purchased focuser, then be sure to drill the hole in the correct spot so that the knobs on the focuser are oriented down when the diagonal is lined up square. Whether you are right or left handed makes a big difference. See Diagram 19. This is so you can use your preferred hand to move the scope around while viewing. This is your opportunity to personalize your telescope to your unique preferences. It's sort of like left or right-handed golf clubs.

Install the focuser in the tube, making sure the diagonal is square. You can check this by looking into the focuser and seeing if you see out the back of the tube and the hole in the back is entirely visible and circular in the diagonal. It does not need to be centered front to back, but does need to be centered side to side. See Diagram 20. If you are using a pvc focuser, so ahead and glue the 1 1/4" tube in place now using pvc cement.

Lining up the primary mirror is easier to do if you have a helper. Insert the primary mirror mount into the tube so the back of the back plate is about 1 1/4" into the tube. Hopefully, it fits snugly enough that it stays where you put it without wobbling around. If it is too tight, take it apart and sand it down (remove the mirror cell from the back plate before sanding!) If the fit is too loose, put one or two wraps of black vinyl tape or masking tape around the edge of the back plate to build it up.

After inserting the primary mirror assembly, look in the focuser and see what you can see. Probably, you will see the side of the main tube - because the mirror is not lined up square (collimated). Have your helper look in the focuser while you go to the back end. Using your fingers or a screwdriver, run all three alignment bolts down against the mirror cell. Don't touch the center bolt! Next, alternately loosen one bolt and tighten a different one while your helper calls out "better" or "worse". You will quickly get a feedback mechanism going that will allow you to precisely center the image of the diagonal and the front hole of the tube in the focuser. See Diagram 21 for what you are trying to achieve.

Once you have centered the mirror, put a low power eyepiece in the focuser and try to focus on a far away object. The moon is ideal. A far off streetlight or porch light is also a good target. If it is daytime, pick some far away tree, car, top of telephone pole, etc. It must be far away. Try to focus on the object by moving the focuser draw tube in and out. When in focus, your focuser draw tube should be racked out about halfway. If it is racked in too close to the tube - you will have to move your mirror cell into the tube further. If it is racked out too far - you will need to move the mirror cell out a little or closer to the back end of the main tube. For the exact distance you want to rack the focuser, you must move the mirror cell exactly that far in the appropriate direction. Every primary mirror has a slightly different focal length, so this is trial and error every time.

If you had to move the mirror cell, you will have to repeat alignment of the primary mirror with the assistance of your helper as you did before (no eyepiece in the focuser!). After re-alignment, test focus again with the eyepiece until you have the focuser racked halfway out and a far away subject is in focus. Try more powerful eyepieces and make sure you can achieve focus with every eyepiece you own and some you can borrow. This is a good time to take off your glasses, if you wear glasses, and focus without glasses. Don't worry about where the focuser ends up with all these different eyepieces and conditions, just that focus can be achieved on a far away object, like the moon or something way far away in every instance.

Now measure the distance from the back of the tube to the back plate at three spots around the tube back and average these measurements. Add 3/8" to the average of measurements and drill three equally spaced holes through the tube only going through the pvc not the wood. Line the back of the plate up using the average measurement derived earlier and screw the three small 1" wood screws through the pvc into the wood of the back plate to hold it in place. After doing all of this, get your helper to assist you in realigning the primary mirror one last time. Glue a piece of felt on the edge of the dust cap and insert it into the end of the tube.

Congratulations! Your telescope is now completed! Now read the next section about selecting eyepieces.

EYEPIECE SOURCES

I would recommend that you consider getting at least two eyepieces - and maybe a third. Your 4.25" telescope has a focal ratio of F-10. To compute the focal length of your primary mirror, you multiply $4.25 \times 10 = 42.5$ inches. Converting to metric, $42.5 \times 25.4 = 1079.5\text{mm}$ - or approximately 1100mm.

To see what the magnification you obtain with a particular eyepiece you divide the focal length of the primary mirror (in millimeters) by the focal length of the eyepiece (in millimeters). For example, a 20 mm eyepiece would give:

$$1100 \text{ divided by } 20 = 55\text{x magnification (power)}$$

This is sufficient magnification to see the rings of Saturn and its moons, the moons of Jupiter with some detail of Jupiter's cloud bands, and the entire full moon. You can also see things like M-13, M-31, and M-57 very clearly.

It is recommended that you get a 20 mm eyepiece as your primary eyepiece.

Also you may want to get a 12.5 or 10mm eyepiece for 100x magnification when viewing the moon or planets. The image is a little bit dimmer, but the detail is greater. On planets and the moon, this not a problem because they are pretty bright anyway. You can see deep sky objects with greater detail, but they are dimmer.

It is recommended you get a 10 or 12.5mm eyepiece as your secondary eyepiece.

If you get a more powerful eyepiece, don't be disappointed if you can't see much detail with it because it will be dark, not too steady, and hard to keep the image in the field of view. Too much power is just as bad as not enough...maybe worse. But there are 4, 5, and 7mm eyepieces available. If you have to have one, get the 7mm. It will give you about 150x magnification. 200x (a 5.5mm eyepiece) is about the maximum practical with this size of telescope. Yes, I know they sell scopes this size marked "625x" at the department store – but that is advertising hype used to sell low-grade instruments – not practical astronomy.

Here are a few places that sell eyepieces:

Lymax's Earth, Sky, & Astronomy 888-737-5050
Astronomics 800-422-7876
Scope City 805-522-6701
Parks 805-522-6722
Orion 800-447-1001
Wholesale Optics of PA 717-842-1500
Edmund Scientific NJ 609-573-6250

DIAGRAM 1

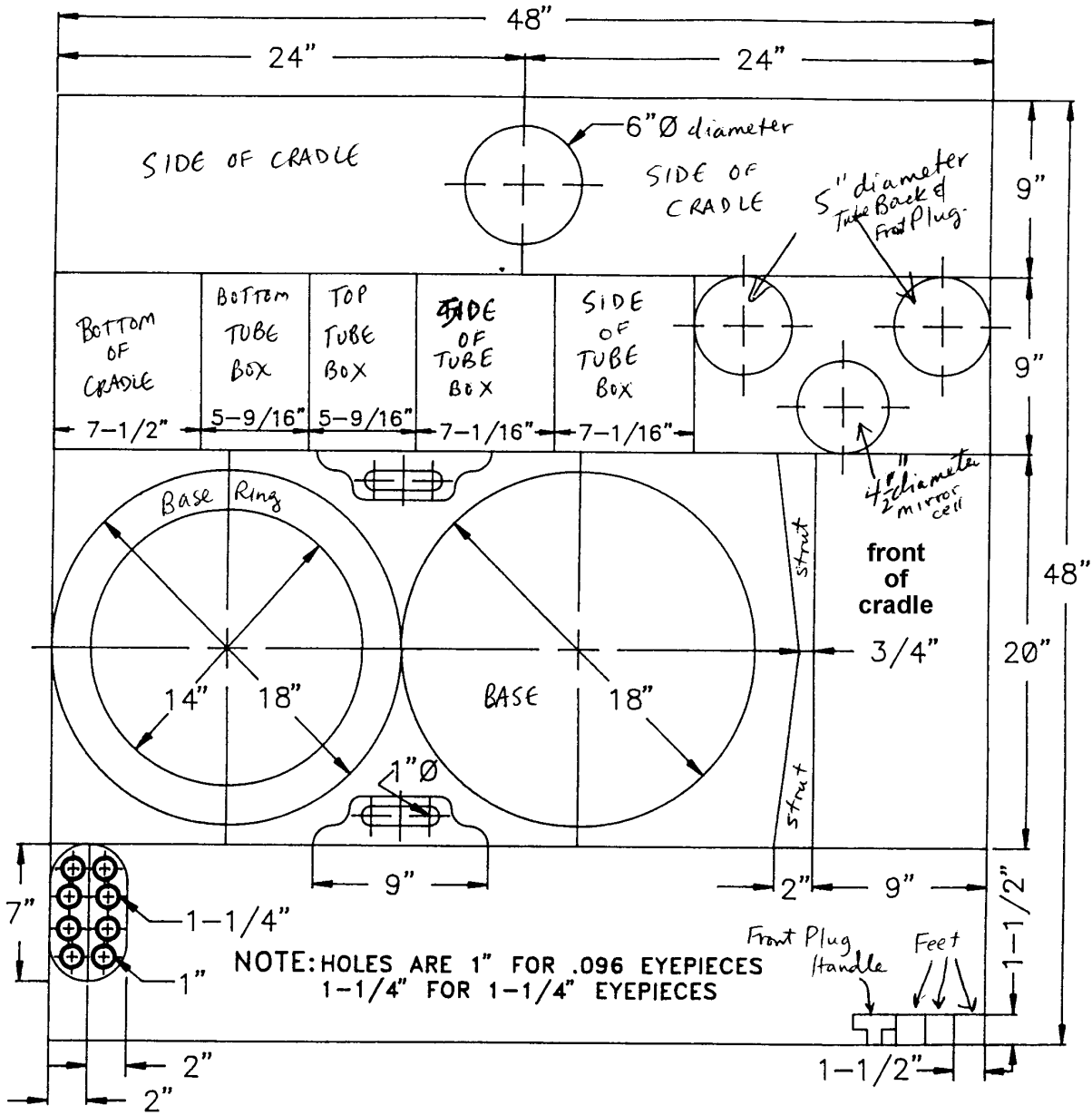

LAYOUT OF PARTS FOR 4.25" DOBSONIAN REFLECTOR FROM 3/4" PLYWOOD

DIAGRAM 2

EXPLODED VIEW OF TUBE BOX ASSEMBLY

GLUE AND SCREW ALL JOINTS
EXCEPT FOR THE TOP

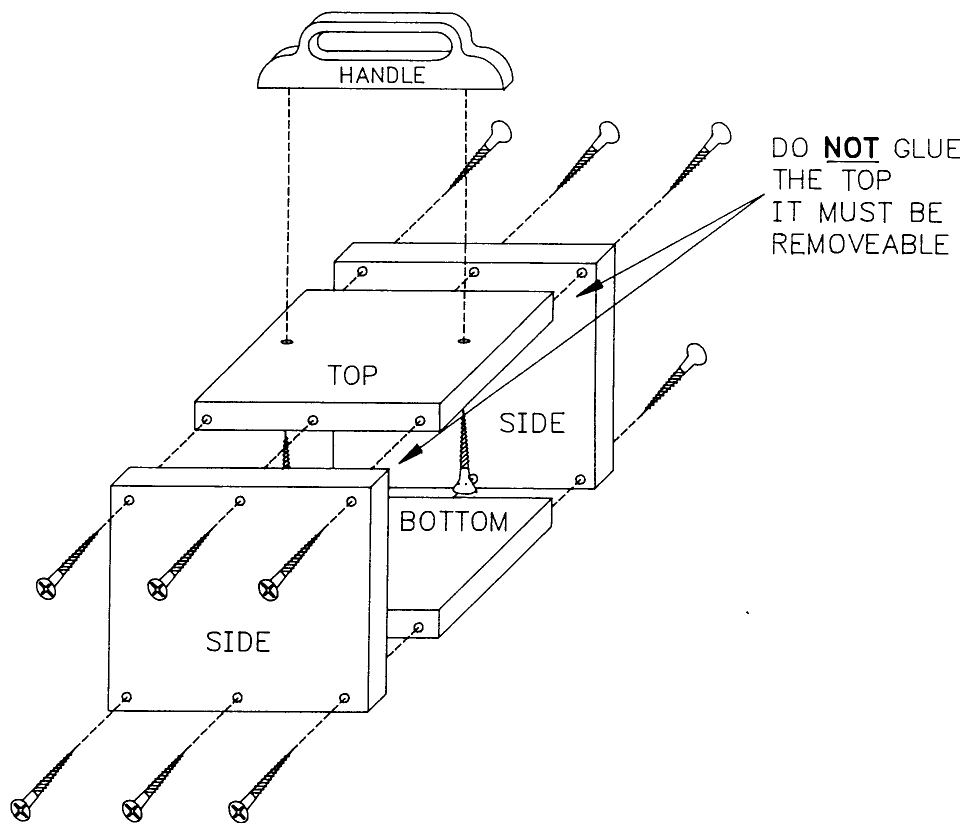

DIAGRAM 3

ASSEMBLY OF CRADLE MOUNT

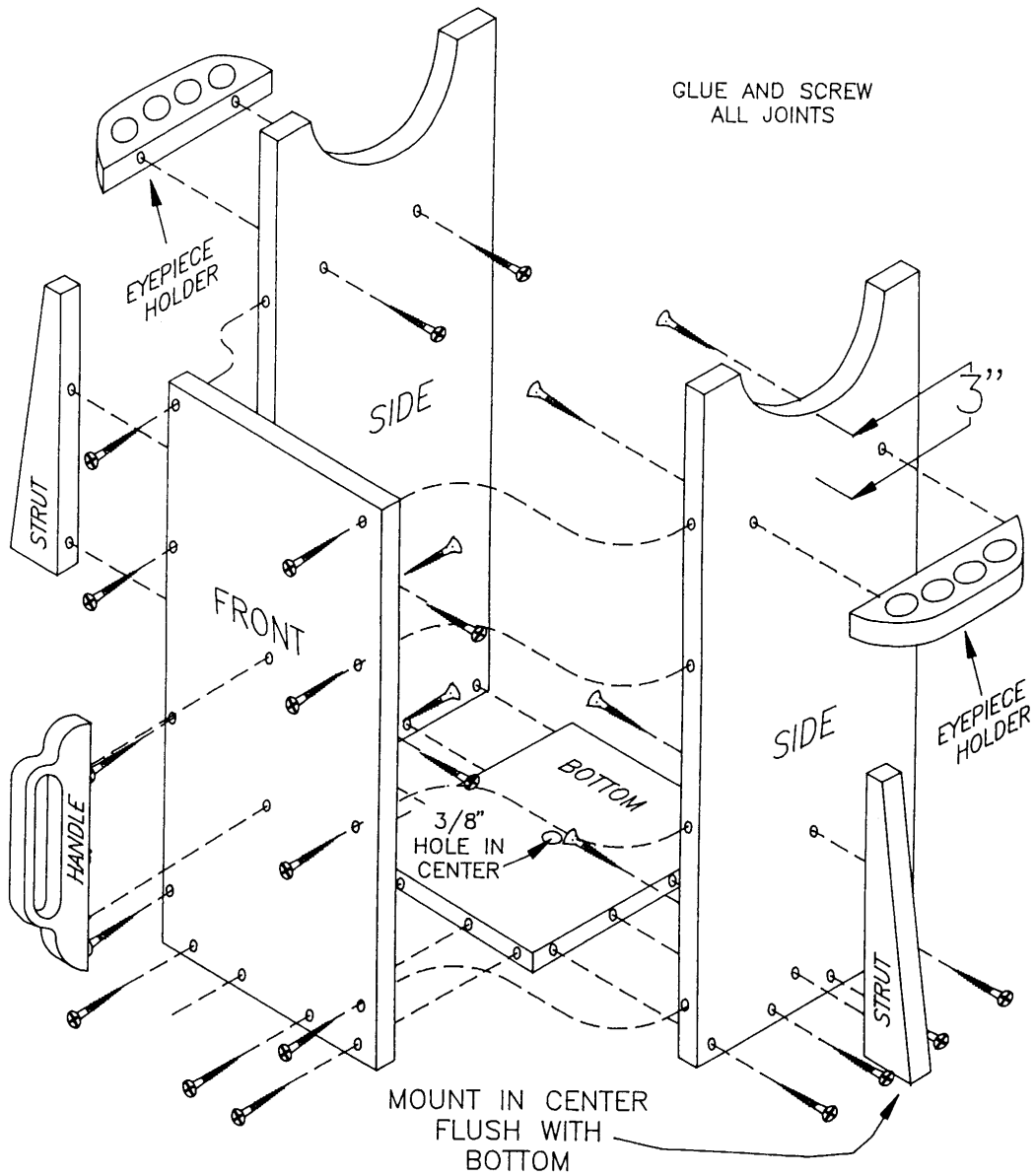

DIAGRAM 4

ATTACHING THE BOTTOM (14") CIRCLE TO CRADLE

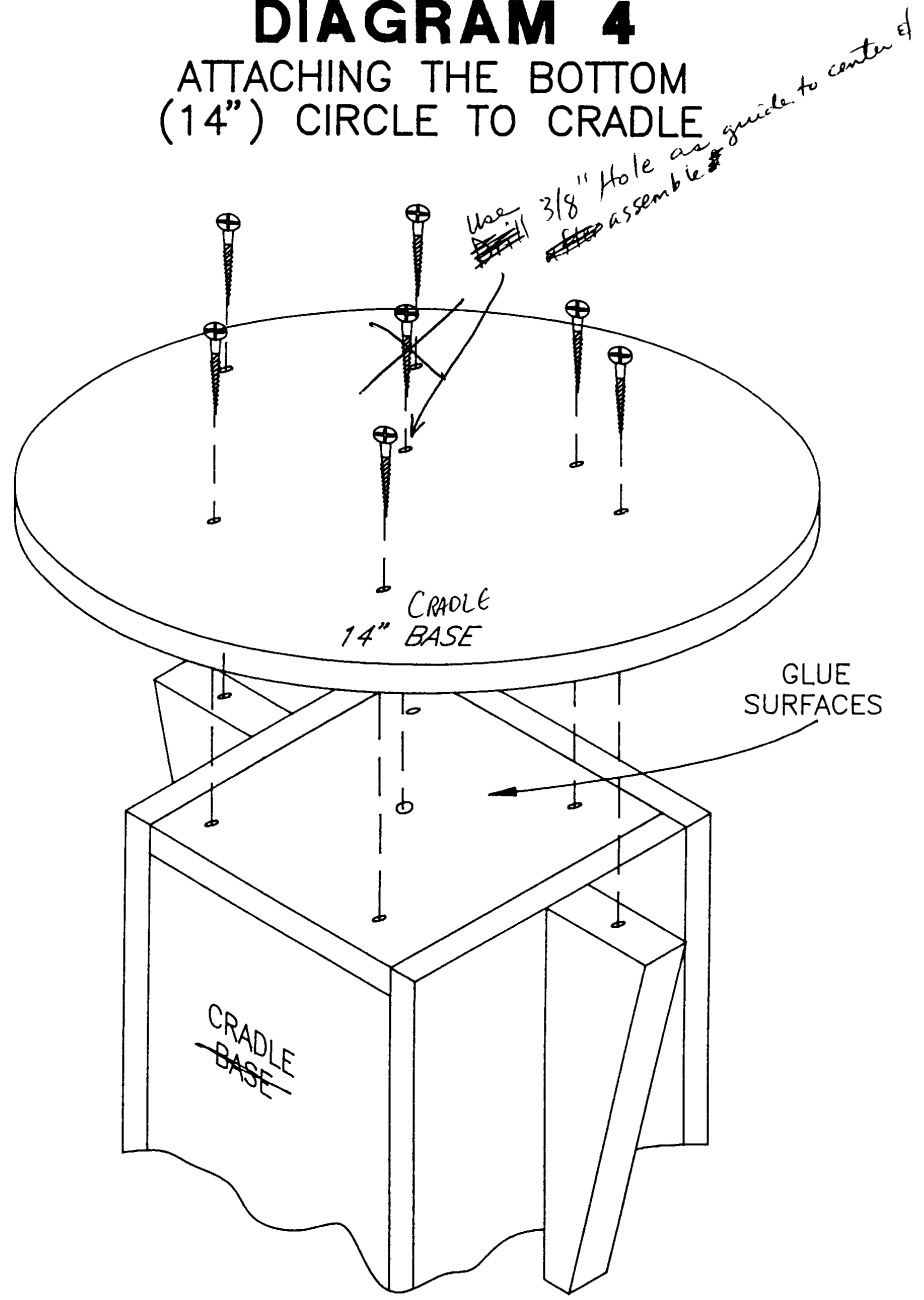
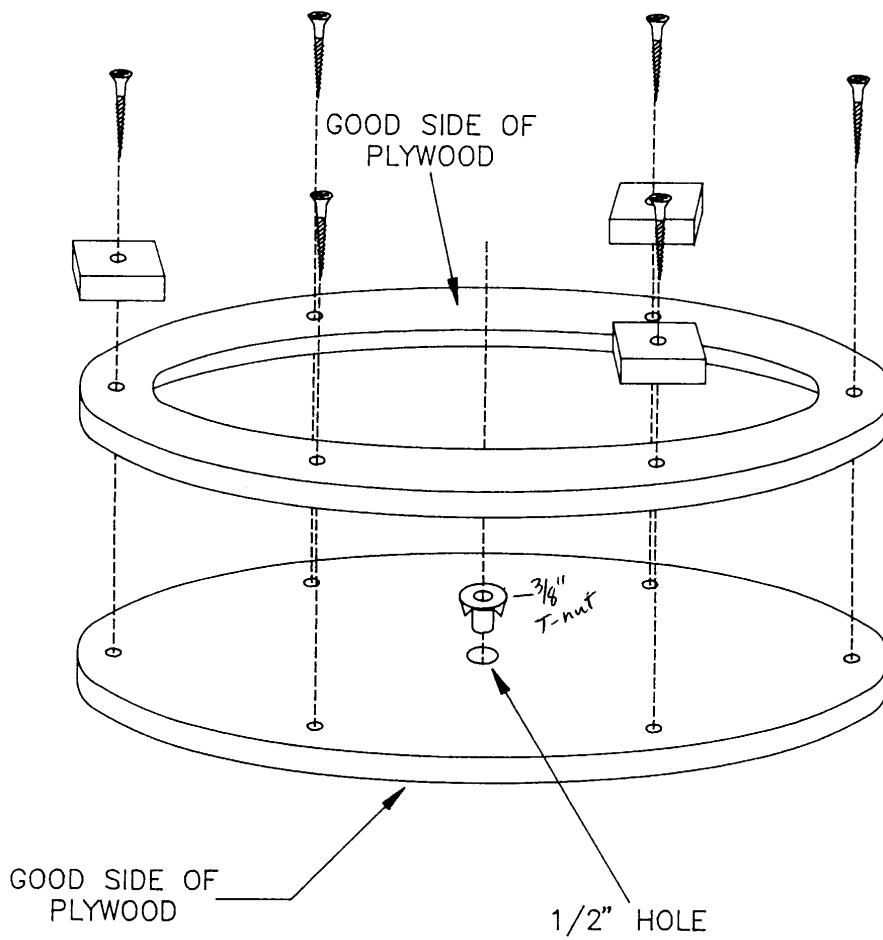

DIAGRAM 5

ASSEMBLY OF BASE RING



GLUE ALL CONTACTING SURFACES

DIAGRAM 6

PREPARING THE MIRROR CELL

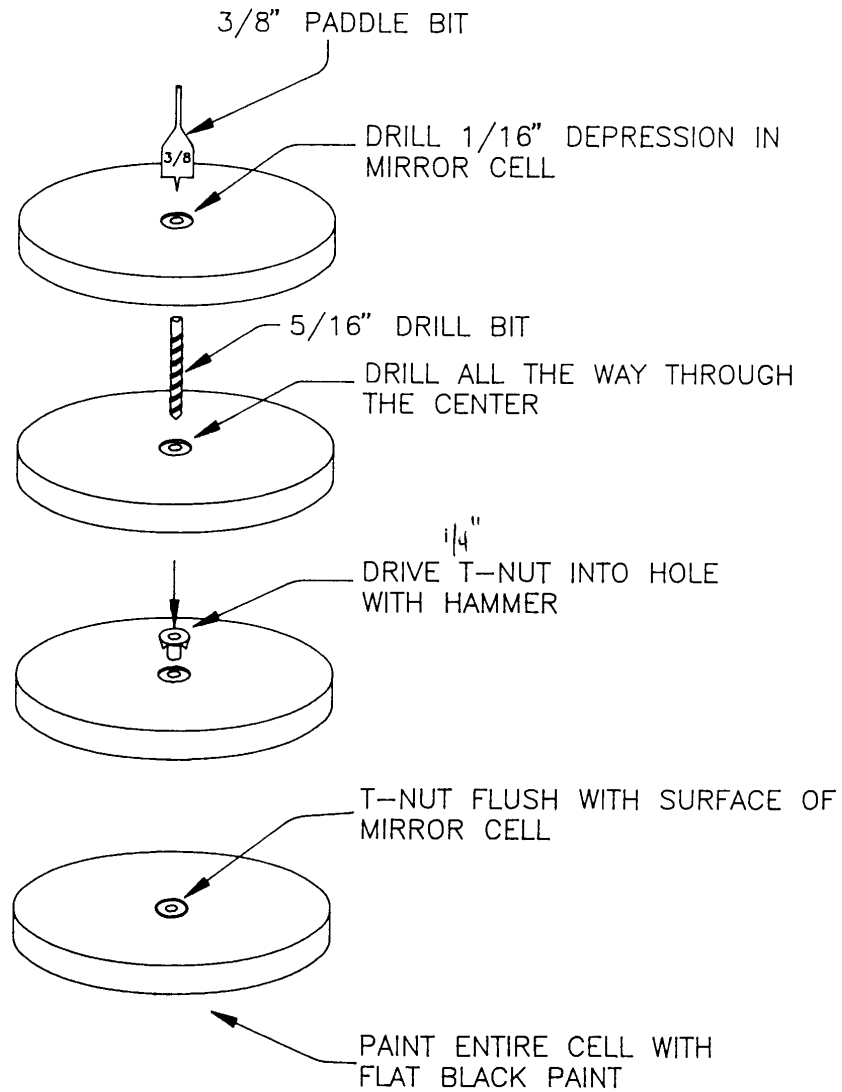

DIAGRAM 7

PREPARING THE BACK PLATE

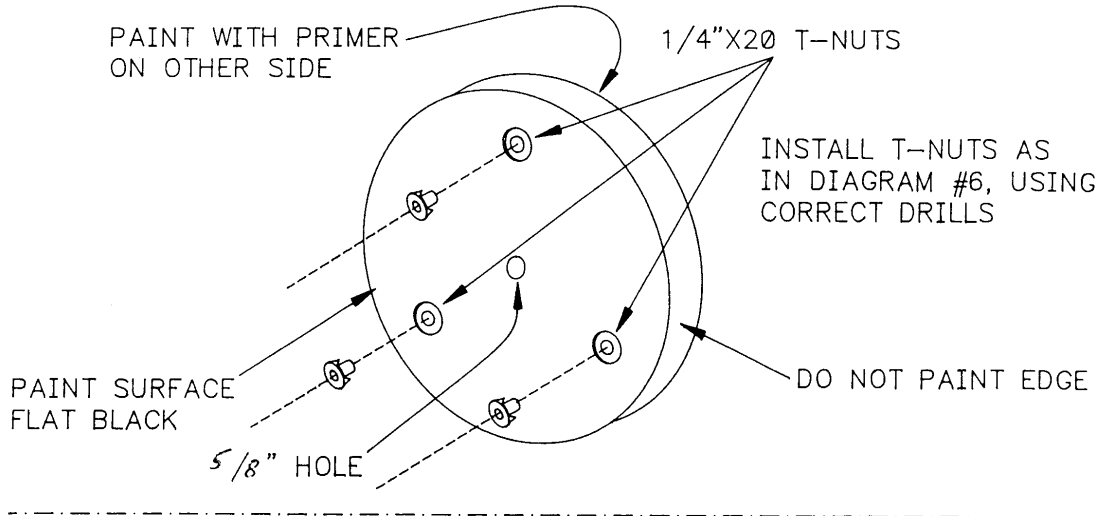

DIAGRAM 8

ASSEMBLY OF DUST PLUG FOR FRONT OF TUBE

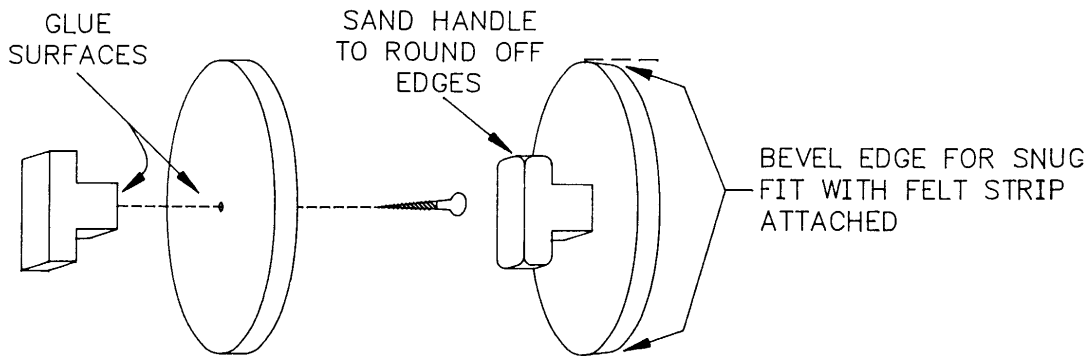

DIAGRAM 9

PVC FOCUSER

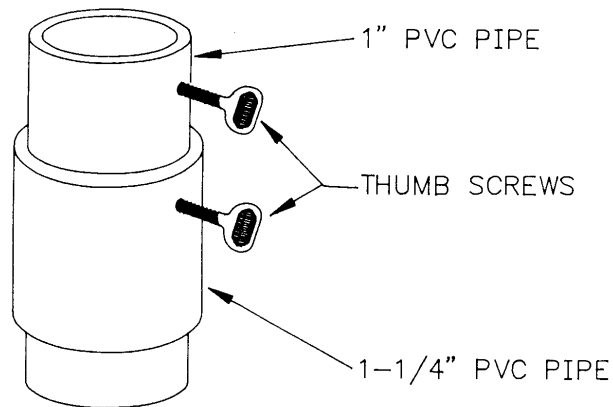

DIAGRAM 10

MOUNTING THE MIRROR CELL

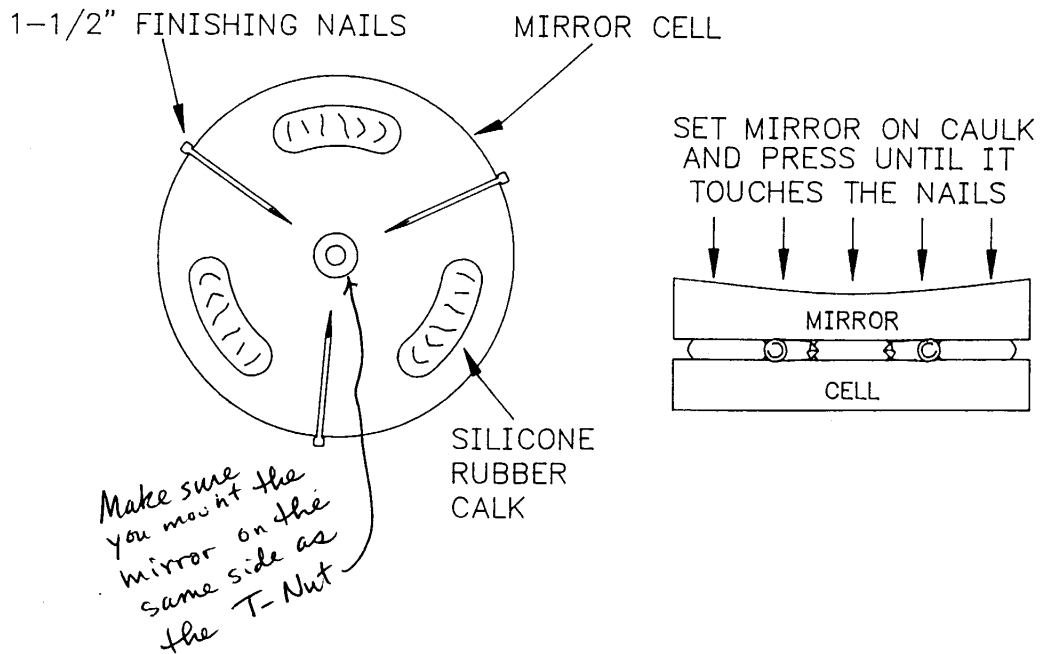
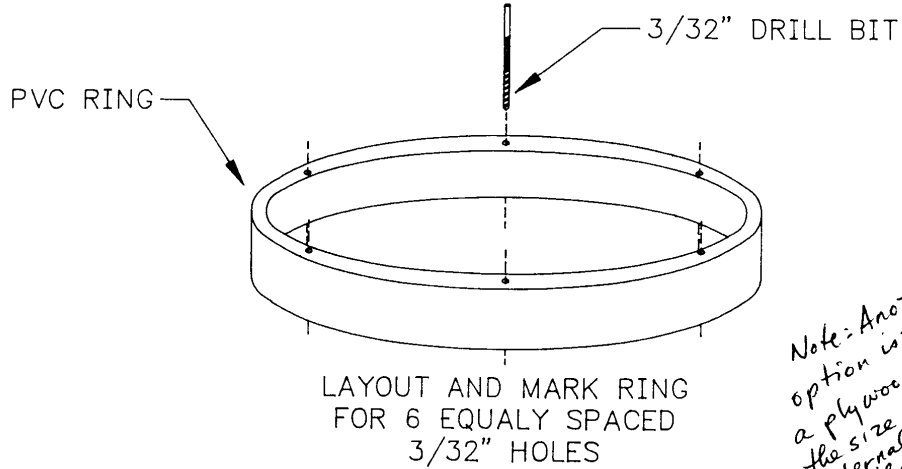

DIAGRAM 11

DRILLING THE RINGS



Note: Another option is to cut a plywood circle the size of the internal diameter of these pieces of tube and attach the tube to it with glue, the nail or screw the plywood to the box.

DIAGRAM 12

ATTACHING THE TUBE RINGS

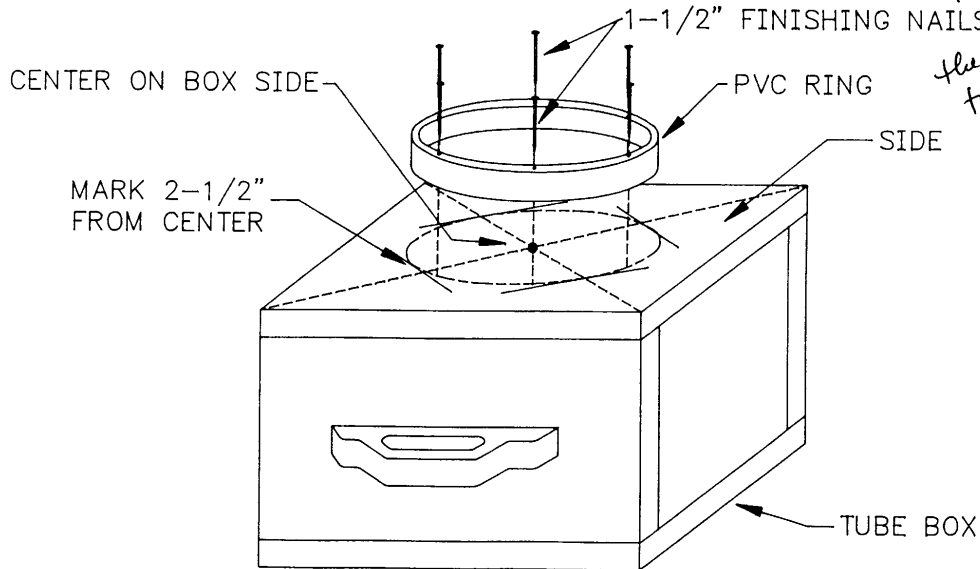

DIAGRAM 13

ASSEMBLING THE MOUNT

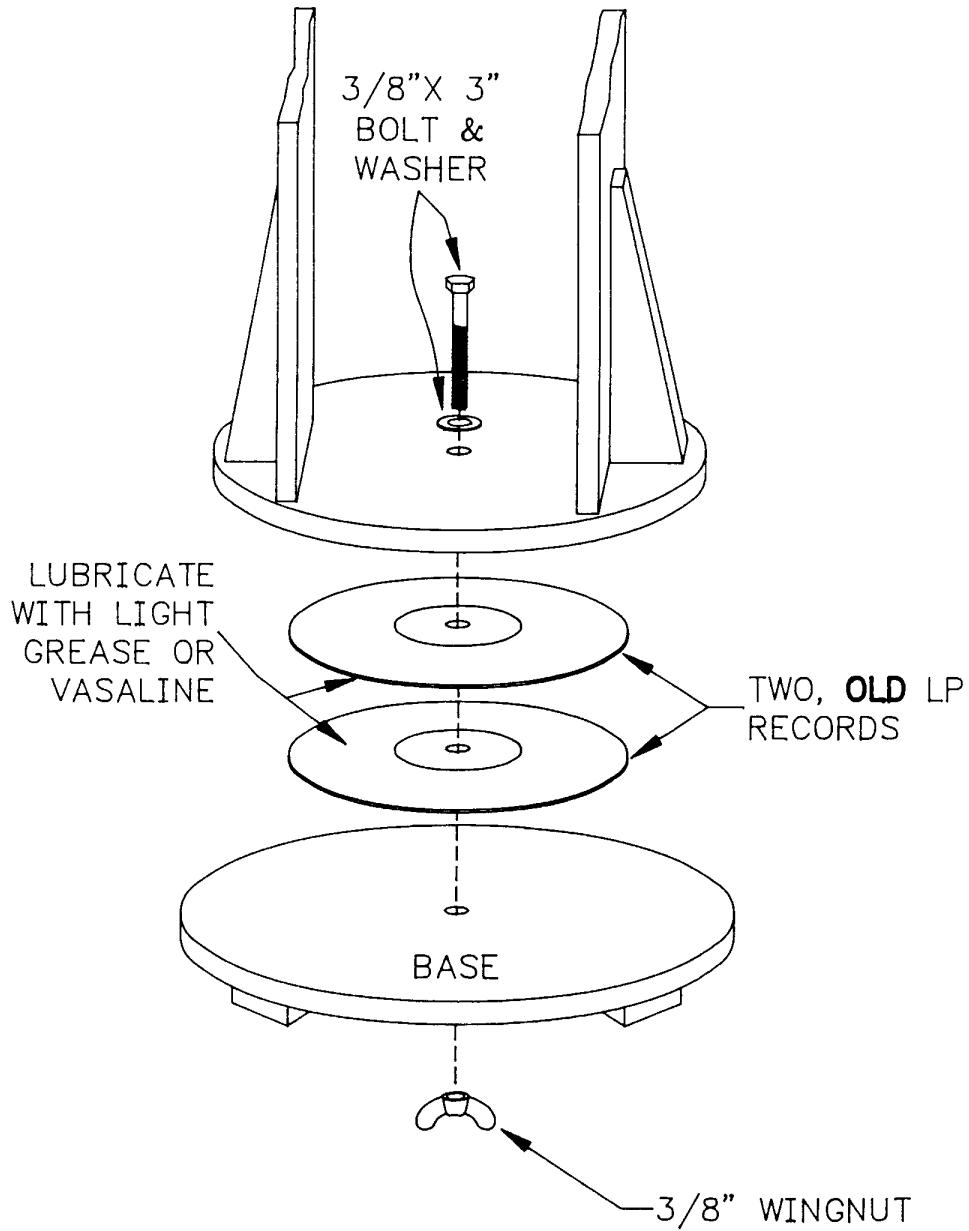

DIAGRAM 14

INSTALLING THE NYLON COASTERS

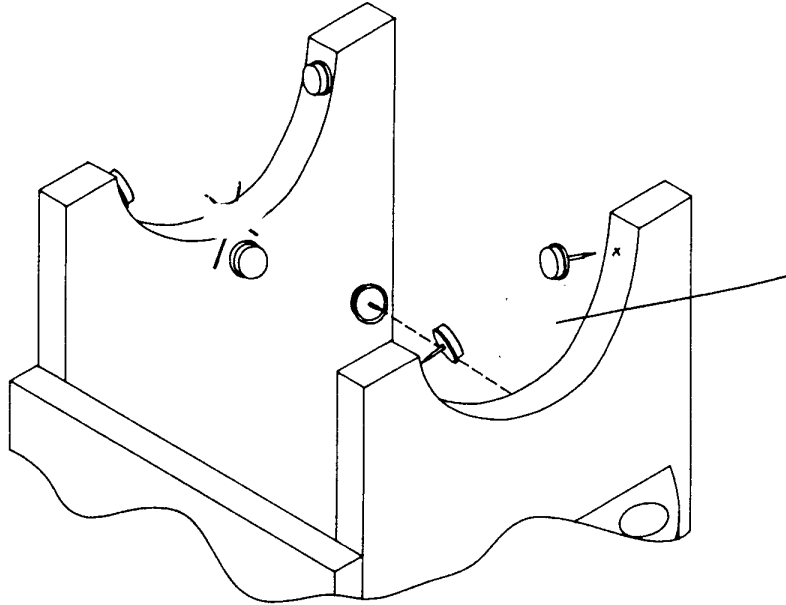

DIAGRAM 15

TUBE BOX RINGS MUST FIT COASTERS

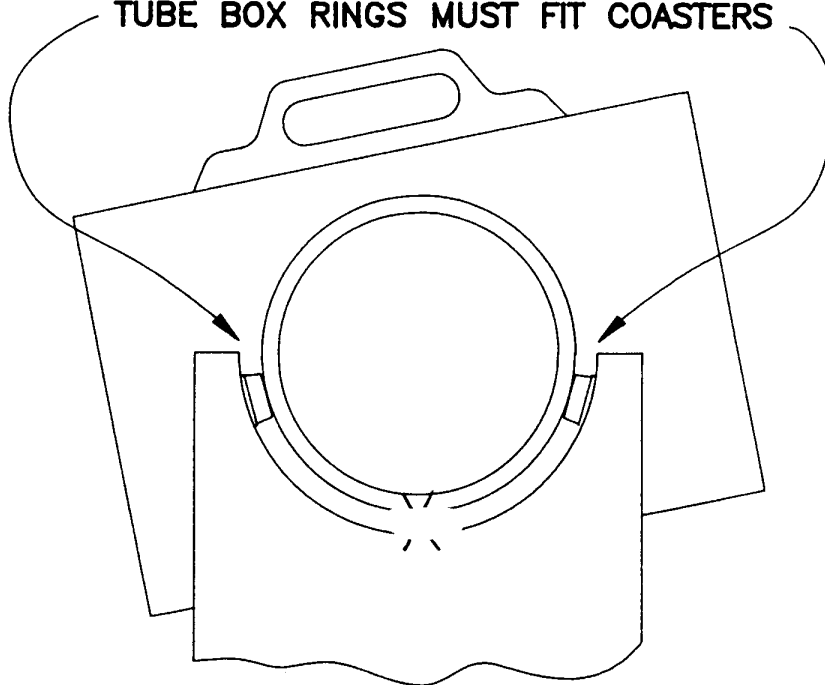

DIAGRAM 16

ASSEMBLY OF MIRROR CELL AND BACK PLATE

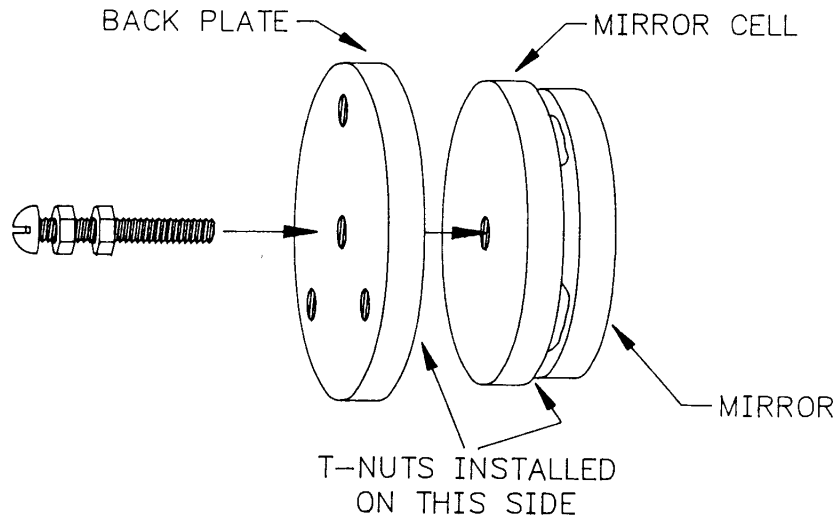

DIAGRAM 17

FULLY ASSEMBLED MIRROR CELL AND BACK PLATE

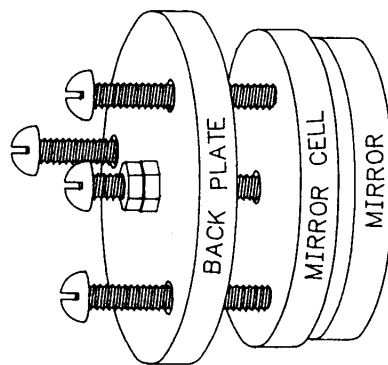
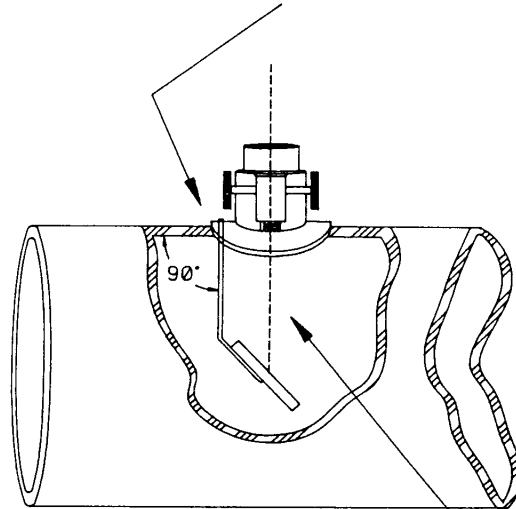

DIAGRAM 18

MOUNTING THE DIAGNAL FLAT MIRROR

WHEN USING SALVAGED FOCUSER
MOUNT DIAGNAL TO LIP OF FOCUSER



WHEN USING PVC FOCUSER
MOUNT DIAGNAL TO TUBE

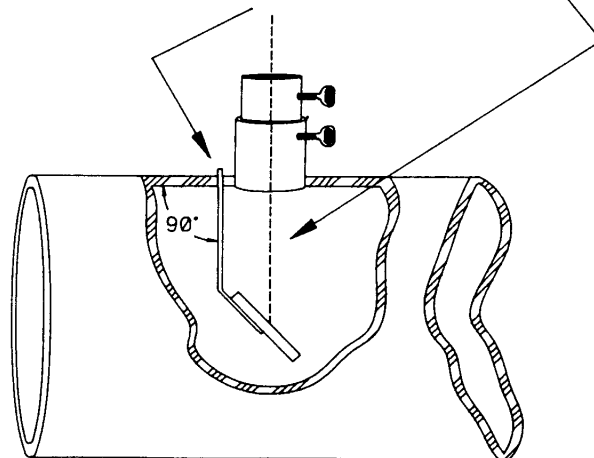

CENTER DIAGNAL
UNDER FOCUSER

DIAGRAM 19

ORIENTATION OF FOCUSER FOR
LEFT HAND OR RIGHT HAND USE

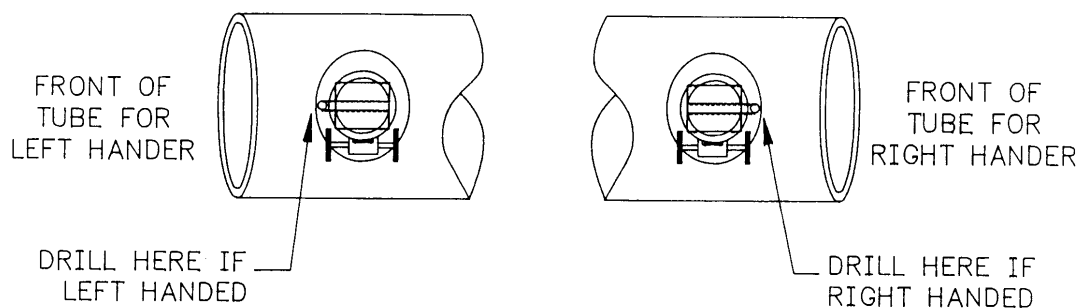
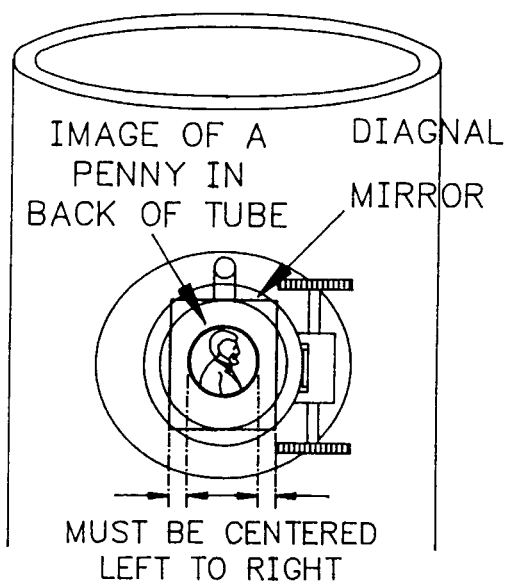

DIAGRAM 20

IMAGE OF
MOUNTED DIAGNAL



YOU SHOULD SEE ALL THE OPENING AT THE BACK AND IT SHOULD BE A CIRCLE

DIAGRAM 21

PROPER ALIGNED IMAGE

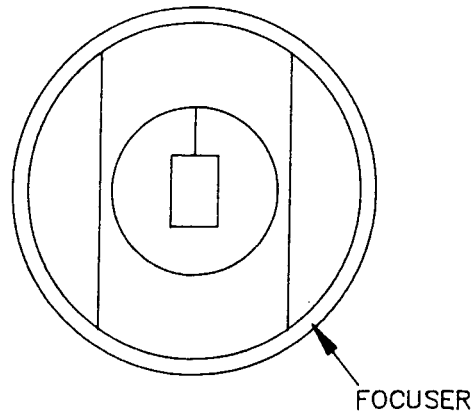

TYPICAL VIEW THROUGH
FOCUSER WITH
EVERYTHING FOCUSED

TELESCOPE BUILDING WORKSHOPS

By Larry Robinson

In June of 1991, I built a 4.25" F10 Newtonian Reflector using plans from Richard Berry's book, *Build Your Own Telescope*. The total cost was about \$125. I took this telescope to the July meeting of the Astronomical Society of Kansas City where I am a member. A good friend and fellow member, David Young, suggested that I organize a telescope building workshop for members of the society who did not own a decent telescope and use group purchasing to get discounts on materials. Dave suggested we use PVC well casing for the tube since he could provide scrap pieces from his well drilling business at no cost. I agreed to take on this project and decided to design the scope with a Dobsonian type mount.

The Dobsonian mount is relatively inexpensive and easy to build. I had already built a 10" Dobsonian from plans out of Berry's book and had a good basic understanding of the workings of this type of mount. The real challenge of this project was Dave's suggestion that we advertise the workshop as "Build your own telescope for \$100!" This budget of \$100 was to prove to be the most challenging aspect of the project, but one which we were able to meet.

Initially, we planned to make focusers out of PVC pipe to 1 1/4" eyepiece size, but Dave called one night saying he had heard about a salvage company in south Kansas City with telescope parts for sale. We met there the next day and for a modest investment, bought two station wagon's full - of used, abused, and some new telescope parts originally from a repair and return center which went broke after the great consumer rip-off during Halley's Comet. Included among all the parts were many .965" focusers of good quality. That's when we decided to make our telescopes with .965" focusers.

We scheduled the workshop for three Saturdays in September. We were to meet and build the telescopes from noon until 4 p.m. on each Saturday. We ended up working from noon until 6p.m, and completing the telescopes in two Saturdays. In all, twelve telescopes were assembled. I made one of them.

The mirrors were ordered from Edmund Scientific and arrived on schedule. Not enough can be said about the service provided by the Edmund Scientific staff. They gave us a nice discount, built extra mirrors when we learned they did not have sufficient ones in stock, and shipped Federal Express at no extra charge when it looked like our delivery might be in jeopardy. I highly recommend going to them for any telescope building parts. Their prices are competitive too.

The basic plan of the workshop was to cut plywood, assemble all the wood pieces, and a primer coat at the first session. This was done. The participants then took their telescopes home to paint them. Our next session was not for two weeks. Everyone was to bring their painted telescopes back in two weeks for final assembly including mounting the mirrors. I took the mirror cells home with me.

The mirrors arrived on schedule two days before the next session and I was able to mount them on the mirror cells using silicone rubber adhesive. The silicone needs to dry for 24 to 36 hours before you can handle it. By the time Saturday rolled around, the mirror cells were ready and the group met again to assemble telescopes. This went smoothly and everyone left with working telescopes. We still planned to meet again on the following Saturday to make eyepieces from some more salvaged piece parts and take a group picture at the annual picnic of the Astronomical Society of Kansas City.

Since the start of the workshop several other members of the ASKC have contacted me wanting to build this telescope themselves. Unfortunately, the workshop was well under way and it would have been difficult to make up lost time. Most have expressed interest in a future workshop and a few have asked me to write out, step by step what to do to so they can do it on their own. That is the purpose of this handbook. I have tried to be very specific about where to get material and what to use and most references are to stores and sources in the Kansas City area. This handbook was originally directed primarily at ASKC members. However, others who may use this handbook will surely find comparable stores or sources in their own community. Also

the section on the focuser includes an alternative of using PVC pipe in case a salvaged .965" focuser can't be found. This is what I did on my first 4.25" and it works quite well - it just doesn't look as fancy.

I was amazed initially to learn that a fairly high percentage of members in our astronomy club do not own a telescope other than a 60 mm refractor. Looking at prices like \$495 for an inferior 4.25" reflector, I can understand why. I think it is important to get new members involved in telescope building and with a decent instrument during their first year with the club. If they can have something portable and always available for quick set-up in the backyard, they are more likely to continue to develop their knowledge and interest in astronomy and become even greater participants in club activities. Our astronomy club, the Astronomical Society of Kansas City, is one of the larger ones in the country, primarily because of the helpful, friendly attitude of the most active members. We have over 270 members, a nice observatory, a wonderful library, tremendous benefactors, and an enthusiastic interest in educating the public. Now, we have a telescope building program for new members which should increase member involvement and help new members to grow in the subject.